

An evolved Sasumata for instant restraint

CERBERUS® security product

SC17



National Police Agency **Award Winner**

A non-combat design for safe evacuation and secure restraint. Detachable mechanism lets you safely distance yourself after restraint.

Press

Video



Wraps around

Band detaches



When pressed against the intruder, the band instantly wraps around and restrains them.

Safe evacuation from a Distance

Create a window of opportunity

Allows for safer and more effective restraint



The detachable design allows you to step away and evacuate while the intruder remains restrained.



Team up for safety.

During the critical window between an emergency call and police arrival, SC17 effectively limits an intruder's mobility, allowing for safe evacuation or coordinated restraint.

By restricting movement, the band makes it easier and safer to subdue an intruder.

Watch the demo video on our official website

Our security products provide a **safe window to escape** or **allow your team to quickly restrain suspicious individuals.**



Visit the Sanokiko official website for more details.

sanokiko Search

sanokiko.co.jp

SANOKIKO
Sanokiko Co., Ltd.

5 Key features of SC17

Instant restraint with a simple press or strike.

Unlike traditional sasumata, allows you to distance yourself after restraint.

Wall-mountable for quick access during emergencies, doubling as a visible crime deterrent.

Specialized for controlled restraint, minimizing risk of excessive force.

Highly effective in open areas without walls or barriers.



3 Key advantages

Easy attachment
with metal fittings and magnets

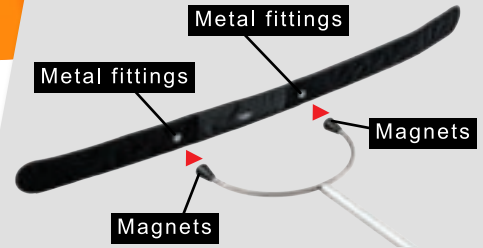

The pole attaches easily to band using magnetic fittings. We recommend keeping it mounted for quick deployment.

Difficult for intruder to remove



The internal design and strong fastening system make it extremely difficult for intruders to remove. For training purposes, it can be easily removed by the user side.

Durable and reusable

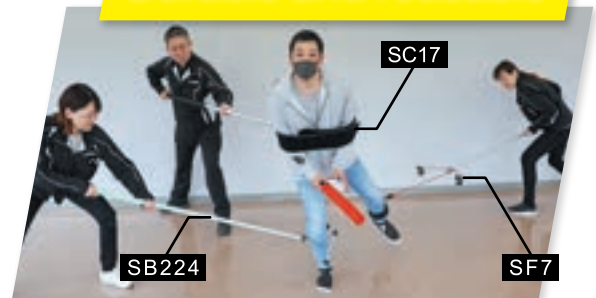

Built to withstand repeated training and real-world applications.

Specifications

*Length and weight are approximate.

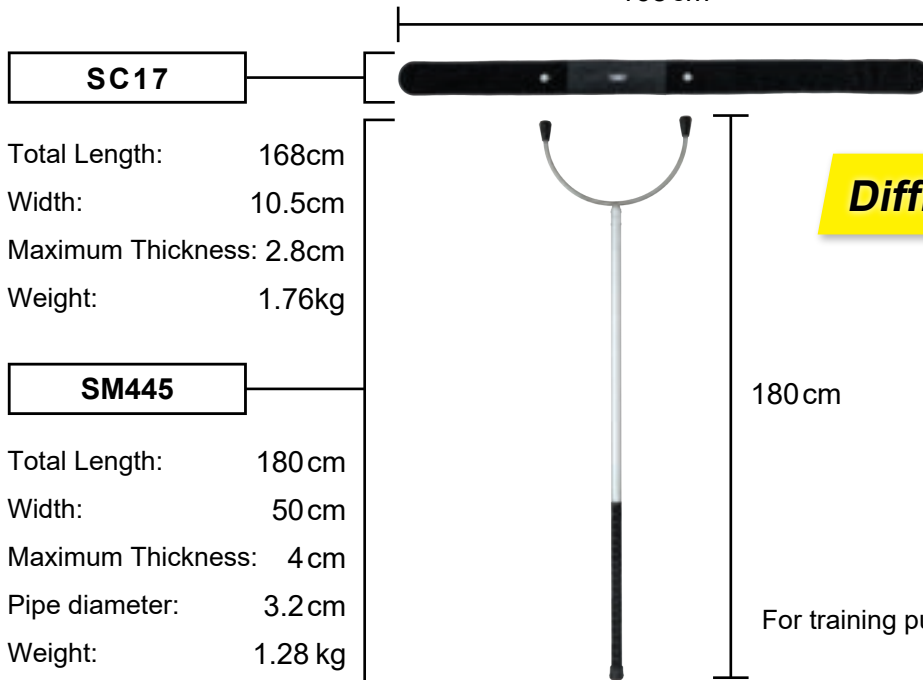

SC17	
Total Length:	168 cm
Width:	10.5 cm
Maximum Thickness:	2.8 cm
Weight:	1.76 kg

SM445	
Total Length:	180 cm
Width:	50 cm
Maximum Thickness:	4 cm
Pipe diameter:	3.2 cm
Weight:	1.28 kg

Main materials

- High-grade stainless steel
- High-engagement hook-and-loop fastener
- Neodymium magnets
- Neoprene
- High-strength nylon fabric
- etc.

Wall mounted holder

Total Length:	24 cm
Width:	4 cm
Maximum Thickness:	8 cm
Weight:	0.34 kg
(Aluminum alloy components)	

